

Low Resolution Version – download the high resolution version here:
www.reflexmarine.com/downloadable-resources/



USER MANUAL

Rev 0.2

Issue date: 13/04/2015

Original Instructions



Introduction

This manual contains information for operating, maintaining and storing the FROG-XT6 personnel carrier.

The key to safe operations is the familiarisation and participation in planning of all crew involved. Please refer to the Crane Transfer Guidelines. This is a separate document that contains comprehensive guidance and information on each element of operation. It is for those researching, planning, managing or carrying out the safest possible crane transfers.

Safe and proper use of the FROG-XT6 is the responsibility of the user after having taken due regard of the information provided in this document.

You should ensure that all safety measures as required by relevant legislation and by good operational practice are in place.

Appropriate training should be provided for all personnel involved in the use of this device.

For the purposes of this manual RML will be deemed to mean Reflex Marine Limited.

Please retain this manual for future reference. Additional copies may be obtained by contacting RML or by downloading the latest version from www.reflexmarine.com/support.

All information disclosed in this document is the property of Reflex Marine Ltd except where otherwise stated. Reflex Marine Ltd reserves all patent rights, design rights, manufacturing rights, copyright and sales use rights thereto, and to any article disclosed within this document except where such rights are expressly granted to others or where not applicable to vendor proprietary parts.

© 2014 Copyright Reflex Marine Ltd, All rights reserved.

Contents

Introduction	1
1 Product Specifications	4
2 Operating Parameters	5
2.1 General	5
2.2 Recommended Operating Parameters	7
3 Using the FROG-XT	8
3.1 Safety Features	8
3.2 Passenger Instructions	8
3.3 Entry and Exit	9
3.4 Deck Crew Instructions	10
3.5 Safety Harness Procedure	11
3.6 Stretcher Mode	12
3.7 Carrying Luggage	15
3.8 Lifting Assembly Connection	16
3.9 Control of Lifting Assembly	17
3.10 Precautions	18
4 Inspection & Maintenance	19
4.1 Introduction	19
4.2 Definitions	19
4.3 Inspection Types	20
4.4 Frequency	20
4.5 Supporting Documentation	21
4.6 FROG-XT6 Inspection and Maintenance Schedules	22
4.7 Load Test Procedure	23
4.8 Pre Use Check	25
4.9 Visual Inspection Checklist Form	26
4.10 Examination Checklist Form	29
4.11 Post Load Test Inspection Checklist Form	33
5 Handling & Storage	34
5.1 Stock Inspections	34
5.2 Forklift	35
5.3 Crane	35
5.4 Securing	35

5.5	Inspection	35
5.6	Preparation for Road Transport	35
5.7	Shipping.....	35
5.8	Storage	35
5.9	Feet Deformation during Storage	36
5.10	Replacement Parts	36
6	Replacement Parts	37
6.1	Introduction	37
6.2	Kits.....	37
6.3	Parts identification	38
6.4	Accessories	38
7	Certificates.....	40
7.1	EC Attestation of Conformity	40
8	Contact Details	41

1 Product Specifications

Table 1 Product Specifications

Model No.		XT6
Dimensions (Nominal)	Width 1	2110 mm
	Width 2 (Across Buoyancy)	2660 mm
	Height	2180 mm
Weight	Maximum Gross Mass	1200 kg
	Tare Weight	540 kg
	Payload - SWL	660 kg
Materials	Frame	316 stainless steel, A4 stainless fixings
	Central Column / Load Plate	316 duplex stainless
	Other Steel Components	All stainless except for floor grating
	Buoyancy	Polyethylene (PE) moulded shell with polyurethane (PU) closed cell foam fill.
	Seat Base/ Seat Back	Polyolefin shell filled with polystyrene closed cell
	Landing Feet	EVA closed cell foam
Operating Temperatures	Standard Model	-20°C to +50°C
	Arctic Model	-40°C to +50°C
Suspension	Springs	4 x stainless steel heavy duty coil spring
	Dampers	2 x stainless steel 400mm recoil dampers
Seating	Seats	6 x full height seats
	Harnesses	3 point, quick release buckle
	Grab Handles	8
Lifting Points SWL	Main	1200 kg (man-riding)
	Backup	1200 kg (man-riding)
	Handling	1200 kg
Wire Rope Lifting Assembly	Safe Working Load	1200 kg
	Wire Rope	Anti-rotation wire rope
Number of Passengers	Standard	6
	Stretcher Mode	1 + stretcher
Luggage Capacity	Light Luggage	Accessory available on request
	Large Luggage Tray	Accessory available on request
Impact Protection	Vertical impacts	Passengers are protected during heavy landings at speeds of up to 4.5 m/s
	Lateral impacts	Passengers are protected from lateral impacts at speeds of up to 2 m/s
Stability	Horizontal	35°, for a load of 1-6 passengers
	Submerged Self-Righting	Up to 180° inverted to the vertical position
Type Approval	Class	EC Type examination certificate No. MAC000005 i01
Quality	System	Manufactured to ISO 9001:2008
Standards	National Technical Standards	UK, BS EN 1993 series: 'The Use of Structural Steel in Building '
	Industry European Standards	EC Machinery Directive EN 14121-1, BS EN 12100-10 Load Test – ILO152 / LOLER
	National Regulations	UK, PUWER / LOLER

2 Operating Parameters

2.1 General

The FROG-XT range has been designed to ensure passenger safety in the most demanding conditions.

There are a large number of factors that affect the safe conduct of marine personnel transfers. These include: crew skill and experience, met-ocean conditions, landing areas, vessel station keeping capability and response to sea conditions, visibility and line of sight. A combination of many factors will determine the risk involved.

2.1.1 Sea State

The FROG-XT6 has a suspension and damping system which prevents passengers from experiencing shock loads up to relative velocities of 4.5 m/s. The maximum recommended significant wave height is based on the maximum relative velocity between the load (or hook) and the deck.

The calculated operational sea states detailed below are based on vertical impact speeds and bio-mechanical considerations. They reflect the ability to withstand such impacts with minimal risk of injury to the human body. However there are many additional factors that may affect the safety of crane transfer operations. These include vessel station-keeping, crew competence, wind and visibility. The operator should always refer to general guidelines on crane transfers operations to assess overall risks.

Technical note:

The calculation for relative velocity used here is based on the European offshore crane standard, BS EN 13852-1:2013. Whereby the maximum anticipated relative velocity between a load and a vessel deck, is given by the following;

$$\text{Relative velocity} = (0.5 * \text{Hook velocity})^1 + \sqrt{(\text{Vessel deck velocity}^2 + \text{Boom tip velocity}^2)}$$

¹ Equal to 1.67 m/s (100 m/min) for lifts below 5 tonnes. Higher crane hook speeds may be available, and it follows that the higher the available crane speed the higher the possibility of a heavy landing or take off. However, with a qualified Crane Operator, it is considered unlikely that the FROG-XT will be landed at full hook speed on a deck rising at full speed.

If there are concerns about heavy landings, operators may wish to consider the following methods to reduce risks; dry runs without passengers, landing in centre of deck where there is less vessel movement, transferring fewer passengers to increase damping, using a hook speed indicator.

Table 2 FROG-XT6 Operating Parameters

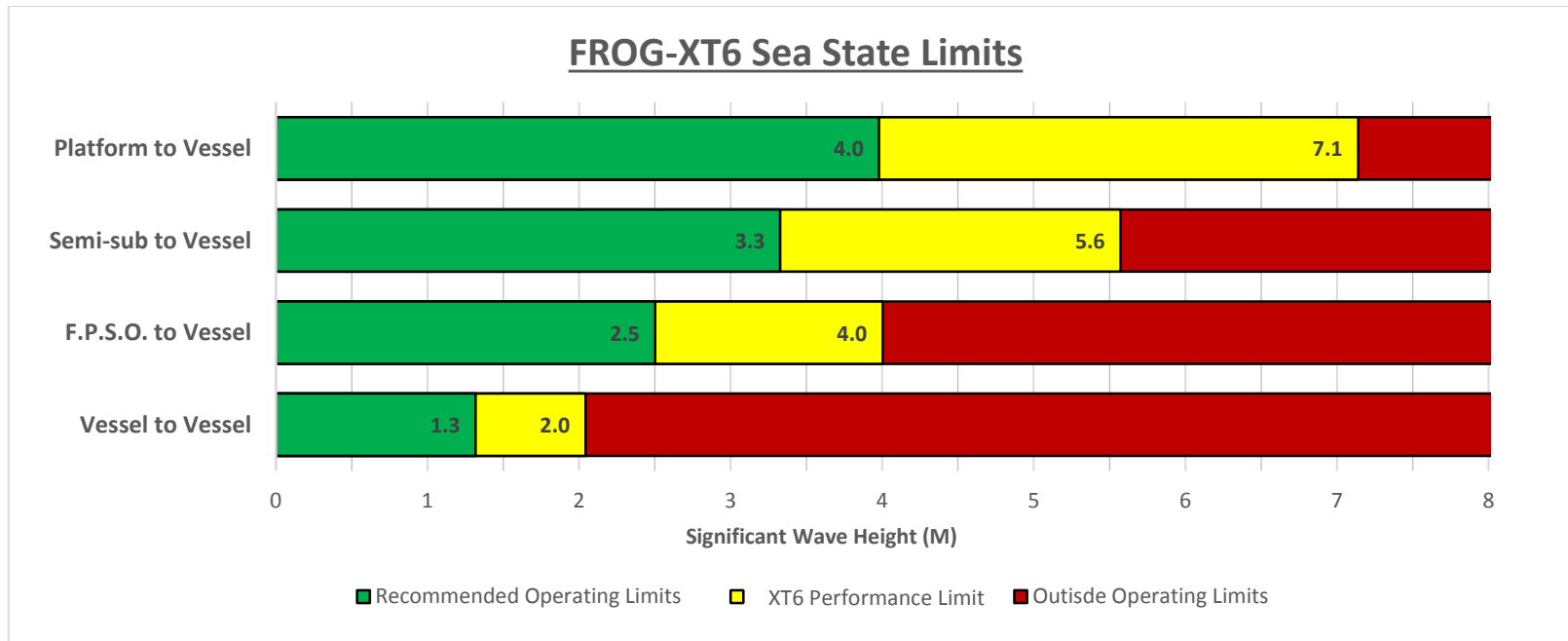

Note:

- **Recommended Operating Limit** - This is the envelope in which it would normally be considered safe subject to due consideration of other risk factors.
- **XT6 Performance Limit** - This envelope is defined by the performance limits of the capsule and the theoretical translation to significant wave height by EN13852-1:2013. However it is assumed that in such elevated sea states other risk factors may become substantial. Operations should not normally be performed in this range without conducting a thorough risk assessment. Contact Reflex Marine if you need assistance.
- **Outside operating Limit** - It is not recommended - sea states are above the safe design envelope of the capsule.

2.2 Recommended Operating Parameters

Table 3 Recommended Operating Parameters

Parameter	Recommendation
Wind Speed	40 knot / 20 m/s (The Frog-XT is very stable in high winds. However crane limits must be observed)
Visibility	Crane Operator should have a clear view of the pickup and set down areas.
Vessel Motion	Pitch 10° Roll 10°
Vessel Station-Keeping	Able to maintain position within a 5 m (16 ft) radius. If a high risk of the vessel losing position exists, disconnect the carrier for passenger embarkation.
Landing Area	Must be clear of obstructions, protrusions, and trip and fall hazards.
Landing Area – Ice / Spills	Ice and spills must be cleaned from landing area prior to transfer.
Landing Area on Vessel	6 m x 6 m (20 ft x 20 ft) landing area is recommended, equivalent to 2m (6.5 ft) clearance all round. Smaller landing areas may be used provided a risk assessment of factors such as deck hazards, weather, sea state, vessel size, station-keeping is carried out.
Landing Area on Installation	4 m x 4 m (13 ft x 13 ft) clear landing area is recommended based on additional 1m entry and exit path on all sides.
Crane Requirements	Crane must be suitable for lifting personnel and properly maintained.
Communications	Radio communication must be established between the Crane Operator and the Vessel Deck Crew and Master.

3 Using the FROG-XT

3.1 Safety Features

Protected Seating Position:

Seats are positioned behind the buoyancy panels and framework. This provides maximum protection and minimises sense of exposure. The arrangement of the seats and entry / exit points allow rapid access and egress, allowing faster and more efficient transfers.

Fall Protection:

3-point harness system and grab handles protect from the risk of falling during transfer.

Vertical impact protection:

- i. Seats are mounted on a suspension system which consists of coil springs and recoil dampers
- ii. Semi-upright secure seat position, cushioned saddle seat
- iii. Impact absorbing EVA foam feet

Lateral impact protection:

- i. Stainless steel frame
- ii. Buoyancy panels
- iii. High backed protective headrest designed to reduce risk of whiplash
- iv. Grab handles and saddle shaped seat cushion for secure seating position

Floatation:

Buoyancy panels ensure the FROG-XT6 floats with both passengers and stretcher above the water line. The FROG-XT6 self-rights up to 180° inverted to the vertical position and is very stable in a range of conditions.

3.2 Passenger Instructions

- i. Enter carrier and take the appropriate seat
- ii. Fasten seat harness
- iii. Keep hands and feet inside the carrier
- iv. Hold the grab handles or the chest straps of the seat harness to keep body stabilised
- v. Place feet onto the floor in front of the buoyancy panel
- vi. Bear weight slightly onto feet in order to adopt a comfortable secure position especially during landing and take-off

3.3 Entry and Exit

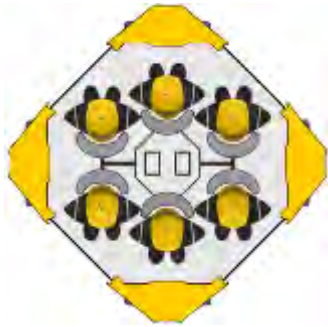

Passenger entry and exit should only be conducted with the carrier in a stable position on deck as advised by the crane operator to the deck crew member in charge of the transfer operation.

Note: All exiting passengers must be clear of the carrier before any new passengers attempt to board.

Each individual seat has a dedicated entry / exit point to prevent confusion and ensure an efficient operation. All passengers must enter and exit from the same direction. Chevrons on the buoyancy panels are present to indicate the direction of entry.

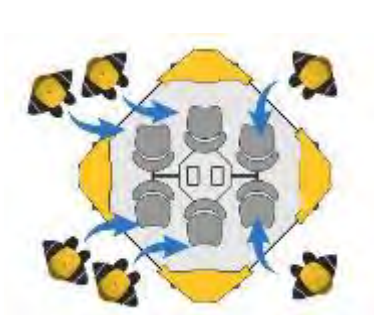

Entry

When advised to do so by the deck crew, passengers should proceed as directed to one of the four entrances and be aware of any tripping hazard. When instructed, all passengers should enter the carrier as illustrated and take their assigned seat.

Passengers should ensure they are securely seated and ensure the seat harness is securely fastened. Grab handles are provided on the tubular upright members either side of the buoyancy panel and passengers should grip these firmly or the harness straps whenever seated. Passengers should never place their hands near the load plate.



Exit

Following landing and when advised to do so by the deck crew, passengers should unfasten the safety harness, stand and exit the FROG-XT6 (note trip hazard) by the appropriate exit.

Passengers should move clear of the carrier as directed by the deck crew, ensuring they remain clear of the lifting assembly.

3.4 Deck Crew Instructions

Briefings

Deliver passenger briefings prior to every transfer lift and contain the following information:

- i. Location specific instructions
- ii. Loading and unloading procedures
- iii. Emergency procedures
- iv. Potential hazards
- v. Seating position

Other Responsibilities

- i. Highlight potential hazards to passengers e.g. trip hazards during entry/exit.
- ii. Remain alert from any hazards as they arise and take appropriate action.
- iii. Check that **passengers' harnesses are secure and correctly fitted.**
- iv. When the carrier is in the static position on deck for passenger entry and exit, the wire rope lifting assembly will be in a static position and may obstruct one or more of the entry / exit points. Ensure passengers remain clear of the wire rope lifting assembly. Deck crew may need to clear the lifting assembly from carrier entrances.
- v. Ensure passengers keep hands clear of any pinch points, as illustrated below.

Figure 1 Pinch Points

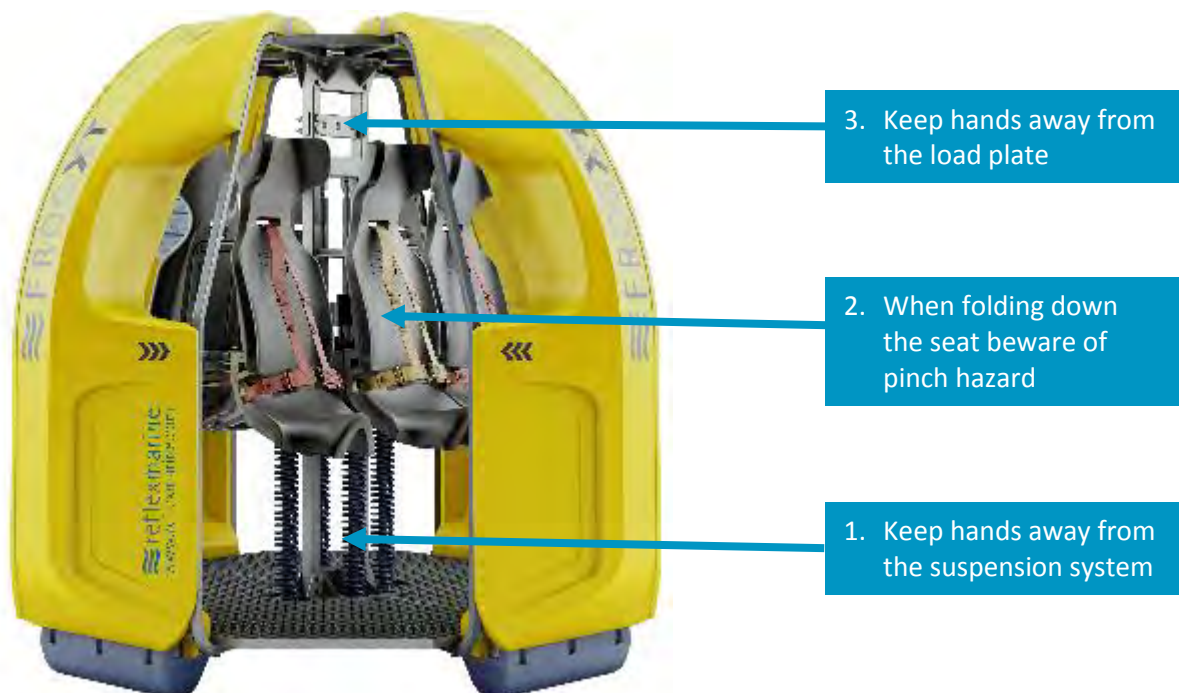

3.5 Safety Harness Procedure

To make passenger entry more efficient, where possible, deck crew or passengers should loosen harness prior to entering the carrier. All passengers should be familiar with seating procedure and practice entry prior to operations.

Step 1
Enter the carrier from the appropriate side of your chosen seating position



Step 2
Pull the harness straps over your shoulders and pull the buckle together



Step 3
Take the lap fastener clip and feed through eye.



Step 4
Fold over the clip and the safety belt is secure



Step 5
Next pull the LOWER straps first



Step 6
Then the UPPER straps to make a tight fit



Reverse the operation for quick release

Step 7
Fold back buckle



Step 8
Pull apart harness straps



Step 9
Exit the carrier on appropriate side



3.6 Stretcher Mode

The following steps outline the procedure to convert the FROG-XT6 into stretcher mode.

3.6.1 Converting to Stretcher Mode

- i. Fold down the three seat backs behind buoyancy panel A.
- ii. Use one 13mm spanner/socket remove the two fittings on each seat as indicated below and fold down each seat (Note: pinch hazards). There is one fitting on each side of the seat to remove.



- iii. These bolts are then replaced in the cross holes on both sides as indicated below.



3.6.2 Stretcher Positioning

The clamp channel has been designed to fit the Ferno Basket stretcher. However the clamp channel can be adjusted in height to accommodate the use of alternative stretcher types.

Please note that not all stretcher types will fit.

The clamp should be checked and adjusted to fit the specific stretcher type in use prior to operation.

- i. Three people should handle the stretcher. Two at the head end/one at the foot end.
- ii. Line up the stretcher as indicated below in figure 1.
- iii. Guide the head of the stretcher onto the folded seats.
- iv. As the stretcher is slid onto the seat the rim of the stretcher should be lined up with the clamp channel.
- v. When in position the head end of the stretcher should have a small (25mm) clearance with the doorframe.

Figure 2 Stretcher Fitting (Buoyancy panels have been removed for illustration purposes only.)

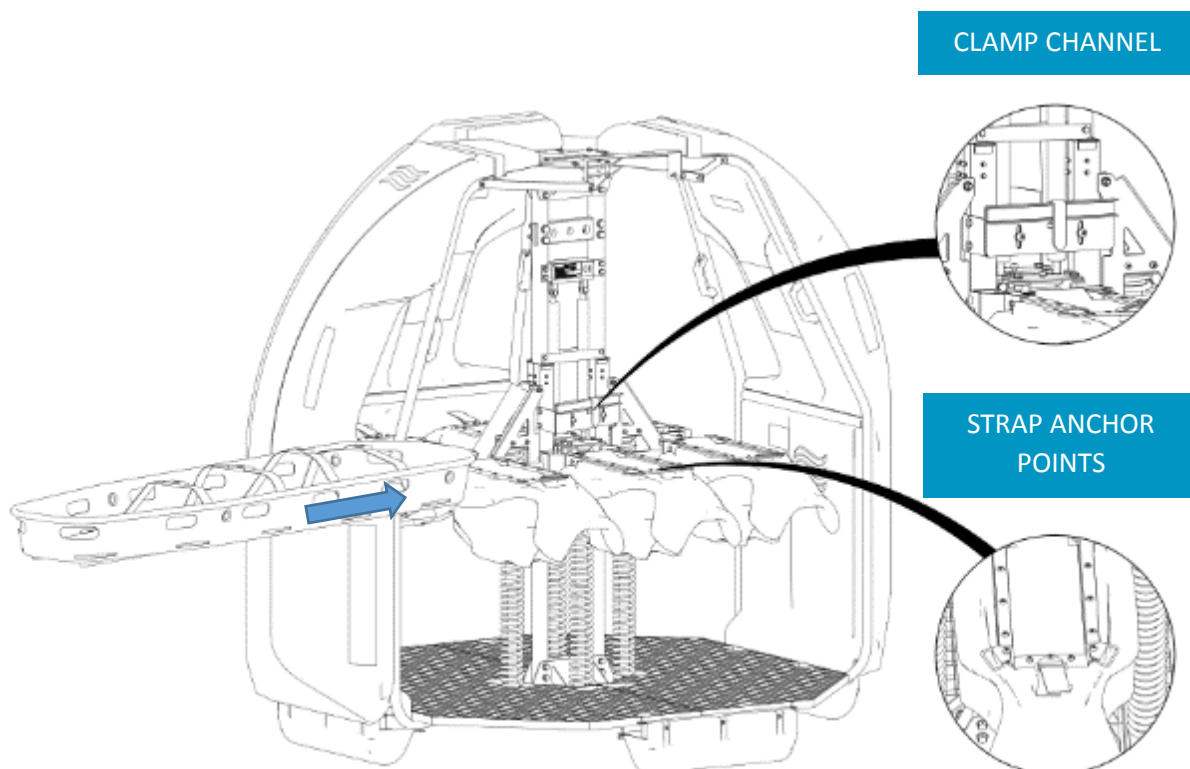

3.6.3 Securing the Stretcher

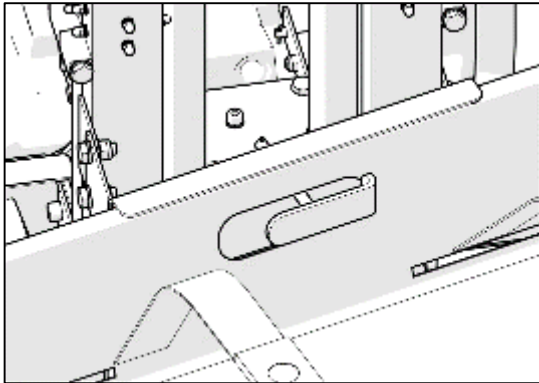

1. Loosen the clamp thumbscrew, then pass the clamp through hand hold in the stretcher

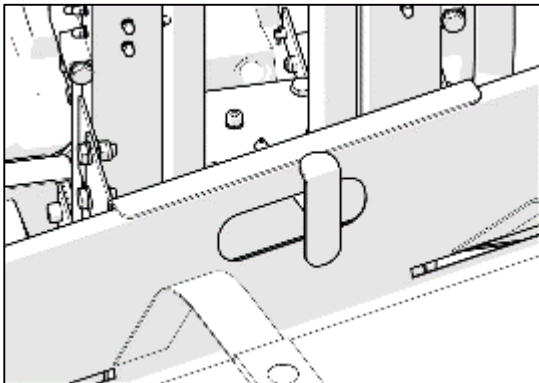

2. Turn clamp 90 degrees with folded edge upward

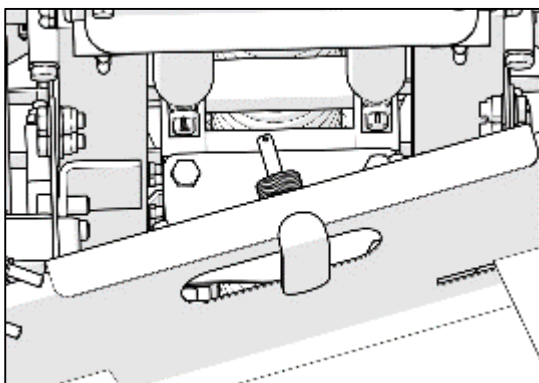

3. Tighten clamp with thumb screw – this should be tight enough to prevent the stretcher from sliding longitudinally



4. Use the supplied stretcher straps to secure the stretcher using the two attachment points

3.7 Carrying Luggage

Luggage may be transferred with passengers, however where practical, passenger luggage should be transferred separately in a cargo box or basket. This will minimise the risks from carrying out additional procedures whilst transferring personnel.

Two types of luggage containers are available accessories: an under-seat light luggage box for small handheld items or under-seat floor containers for larger kit bags.

The following recommendations should be considered when transferring luggage:

- i. The weight of the passengers plus the luggage should not exceed the SWL.
- ii. All luggage items should be handled by deck-crew, not passengers, to minimise the time passengers spend in the hazardous zone.
- iii. Items should be secured prior to passenger boarding, and removed after passenger exit.
- iv. Small, individual, hand-carry items such as laptop bags may be secured directly underneath a seat in one of two light luggage boxes. Items should not exceed 400 mm (*w*) x 300 mm (*l*) x 120 mm (*h*) (16" x 12" x 5") and 5 kg (11 lbs) per item.
- v. Larger luggage may be secured in under seat floor containers. It is recommended that no more than 15 kg of luggage per person is loaded. Luggage should fit comfortably in the containers provided and remain secure. Height of luggage placed underneath seat should be restricted to 200 mm (8") so that it will not impede the damping system.

Figure 3 Luggage Height

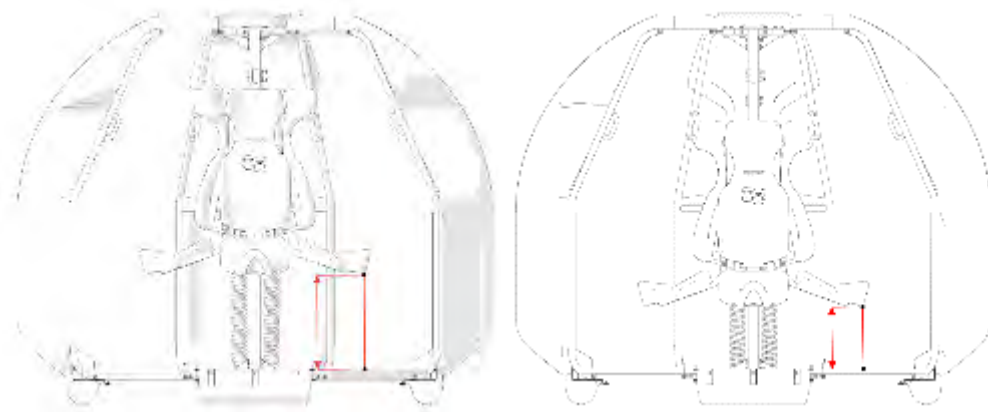

- vi. Heavy or large materials such as tools, boxes, or equipment should be transferred separately in suitable cargo box or basket.

3.8 Lifting Assembly Connection

Figure 4 Lifting Assembly

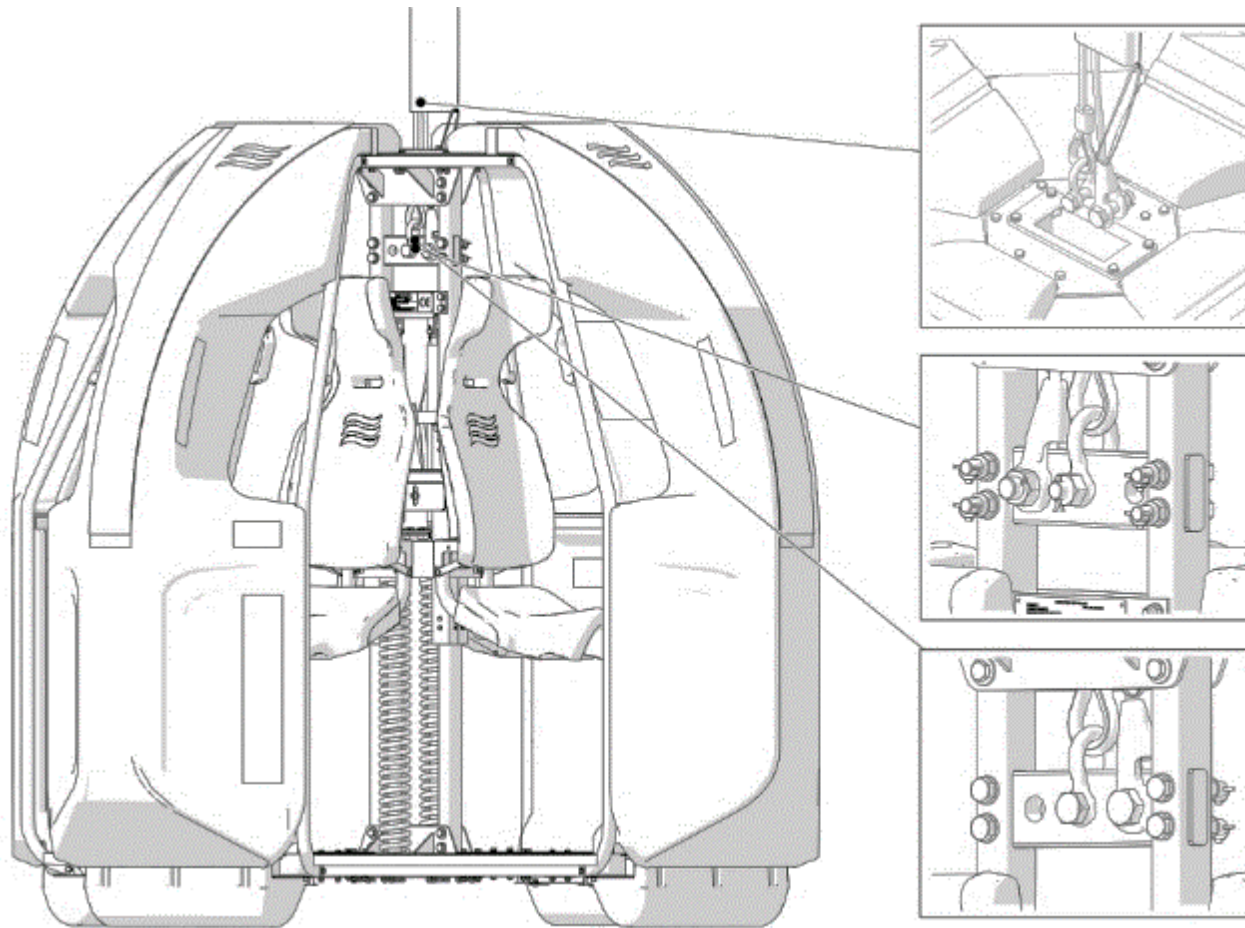

Lifting assembly is fitted to the FROG-XT by initially lowering it through the letter box opening at the top of the carrier.

The lifting assembly is fitted with two different terminations. The main leg is fitted with a bow shackle and the back-up leg is fitted with a spelter socket.

The main leg connects to the centre hole in the load plate and the backup leg connects to the larger of the two remaining holes

A handling line can then be fitted to the free hole in the load plate

3.9 Control of Lifting Assembly

The FROG-XT6 is designed to stay firmly on the deck of the vessel whilst passengers are entering or leaving the capsule. The Crane Operator must maintain slack in the line upon landing to allow for the vessel movement.

Table 4 Control of lifting assembly

Parameter	Recommendation
Ideal Sling Length	The recommended limits in this section are based on the use of the standard FROG-XT wire rope lifting assembly length of 30 ft (9 m).
Shorter Slings	For the use of shorter lifting assemblies an additional risk assessment combined with dry runs should be performed to establish safe operational routines and weather conditions. Using a shorter sling set also increases risks associated with the hook block being in close proximity to the capsule

Table 5 Sling lengths

Sling Length	Recommended Slack	Allowable Drift	Distance to the Crane Hook
30 ft	10 ft	22.4 ft	20 ft
20 ft	10 ft	17.3 ft	10 ft
10 ft	8 ft	9.8 ft	2 ft

Figure 5 Lifting assembly slack

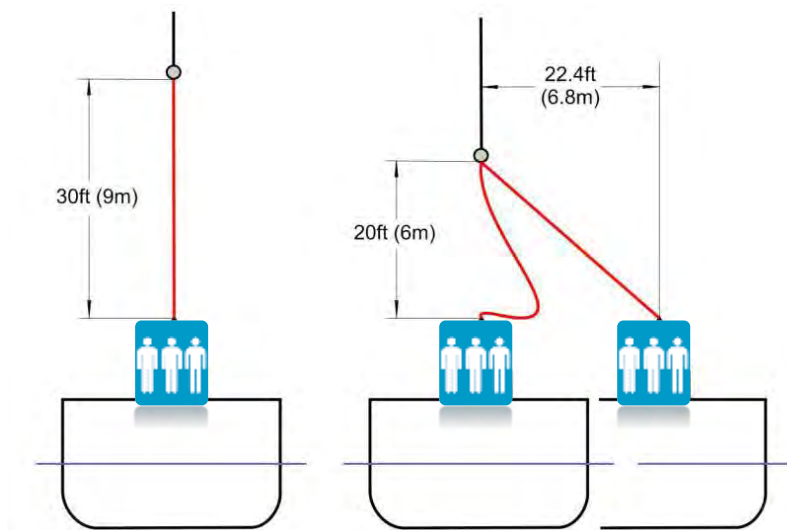

3.10 Precautions

- i. Passengers must remain seated, holding the grab handles and ensure that head, hands and feet remain inside the carrier at all times during the transfer operation.
- ii. Passengers should be aware of the potential trip hazard of the floor grating when entering and exiting. This should be highlighted during the pre-transfer briefing. Deck crews should reiterate awareness of trip hazards to passengers during entry and exit.
- iii. Deck crew should always double check that all passenger harnesses are secure and correctly fitted prior to any transfer.
- iv. **Deck crew should always check that passengers' hands are** on the grab handles.
- v. When the carrier is in the static position on deck for passenger entry and exit, the wire rope lifting assembly will be in a static position and may obstruct one or more of the entry / exit points. Passengers must take care to remain clear of the wire rope lifting assembly and, if obstructed, should wait until it is held clear by the deck crew.

4 Inspection & Maintenance

4.1 Introduction

Following the recommended procedures set out in this section will help to ensure safe operation of the FROG-XT6.

4.2 Definitions

Transfer Lift

A transfer is defined as one pickup and put down when passengers are on board, or when the unit carries more than its tare weight.

Usage Category

This is defined by the number of transfer lifts per year. There are four different usage categories from low to very high.

Critical Parts

These are the identified set of load bearing parts.

Competent Person

A competent person is a person who has appropriate practical and theoretical knowledge and experience of the equipment. This will enable them to detect defects and weaknesses and to assess their importance in relation to the safety and continued use of the equipment. It is essential that the competent person is sufficiently independent and impartial to allow objective decisions to be made.

Non Destructive Testing

Although not considered necessary, some operators choose to adopt a dye penetrant crack inspection prior to any re-installation of a critical part.

4.3 Inspection Types

Table 6 Inspection Types

Inspection Type	Description
Pre-use Check	A check of key areas prior to each use without dismantling the assembly. Carried out by a competent person.
Visual Inspection	A careful and critical assessment of the components, carried out by a competent person without dismantling the assembly.
Examination	A careful and critical assessment of the components, carried out by a competent person. This should include dismantling the assembly and performing a visual assessment of the condition of each component, supplemented by other means such as measurement and non-destructive testing as considered necessary. For lifting assemblies this should include a visual inspection of the condition of each leg.
Post Load Test Inspection	A careful and critical assessment of the components following a proof load test. Carried out by a competent person without dismantling the assembly.

All inspections should be:

- i. Performed by a competent person
- ii. Carried out as per the frequency indicated in the usage table
- iii. Formally recorded

4.4 Frequency

The recommended frequency and type of inspection, test and maintenance is shown in Table 7. (SEE OVER). Please note:

- i. If any doubt exists regarding the usage then the maintenance strategy should revert to a more conservative higher usage category. This should also be considered if there is any concern over heavy impacts or overloads.
- ii. This recommendation applies to change out of components parts only and does not replace or alter the inspection intervals as prescribed by the relevant legislation.
- iii. The check, inspection, examination and test routine as detailed in this document should always be carried out on schedule.
- iv. Where the carrier has experienced heavy vertical or lateral impacts, or sustained substantial damage, a detailed examination should be carried out to ensure integrity before conducting any further lifts. Details of all damage should be recorded in a damage report. Details of the cause of the damage should also be recorded, if known.

If damage to the frame has occurred, welds should be examined for cracks using the dye penetrant method.

- v. Details of all repairs or modifications carried out should be recorded and copies of damage and repair / modifications reports should be sent to the party controlling the use of the FROG-XT.
- vi. Lifting assembly covers should be removed if the wire rope lifting assembly is removed from service.
- vii. Contact RML or one of our approved partners for technical advice on inspection, testing or maintenance. It is always helpful to provide detailed photos and reports along with any query to support@reflexmarine.com.

4.5 Supporting Documentation

Customer drawing pack

Every FROG-XT6 comes with a drawing pack that contains all of the relevant drawings to aid in its maintenance. This pack contains the following:

- i. Assembly drawings
- ii. Replacement parts, kit drawings
- iii. Torque settings
- iv. Operational stickers
- v. Bill of materials

Certification pack

Every FROG-XT6 comes with a certification package, which includes, but not limited to, **manufacturer's declaration of conformity**, all of the critical parts certificates, load test certificates and the third party release note and checklist.

If any further certification is required please contact RML.

Component certification

RML retains copies of the certification for all units and components involved in their manufacture. Replacement copies are available on request.

4.6 FROG-XT6 Inspection and Maintenance Schedules

Table 7 FROG-XT6 Inspection and Maintenance Recommendation

FROG-XT6 RECOMMENDED INSPECTION AND MAINTENANCE SCHEDULES							
Usage Category No of Transfer Lifts per year	Pre Use Check	Visual Inspection	Examination	Wire Rope Lifting Assembly Replacement	Load Test Post Load Test Visual Inspection Critical Parts Replacement	Suspension System Replacement	Unit Replacement ¹
Low <100	Conducted Prior To Every Use	6 months	12 months	12 months	36 months	4 Years	12 years
Medium 100 - 500		6 months	12 months	12 months	24 months	3 Years	8 years
High 500 - 2000		3 months	12 months	6 months	12 months	2 Years	6 years
Very High 2000 - 5000		3 months	6 months	3 months	6 months	1 years	4 years
<i>¹This may be extended subject to a 'condition & service assessment' carried out by Reflex Marine or an Approved Partner</i>							

4.7 Load Test Procedure

Table 8 Load Test Requirements

Question	Response
When should a Proof Load Test be conducted?	<ul style="list-style-type: none"> i. After replacement of any critical parts. Does not apply to replacement of lifting assemblies. ii. After any suspected damage arising from overloading or impact. iii. If the history of the unit is uncertain. iv. If the inspection data plate is missing, illegible or out of date.
Who should conduct this test?	<ul style="list-style-type: none"> i. Independent 3rd party. ii. A competent and certified test person.
Does this test require a formal record?	Yes.
What equipment is required to perform this test?	<ul style="list-style-type: none"> i. Loading weights or sand bags (1860 kg). ii. Certified weighing scale or load cell. iii. Lifting equipment certified for > 5 Tonnes SWL. iv. A ladder or top access platform. v. An inspection frame or floor matting. vi. Good lighting.

Table 9 Load Test Instructions

Item	Instruction
Components Under Test	<ul style="list-style-type: none"> i. Main Lift Point / Backup Lift Point / Handling Point ii. Central Column Load Bearing Assembly. iii. Seats and Floor Structure.
Test Proof Load	1860 kg (4,100 lb)
Test Proof Load Distribution	<p>At the discretion of the competent person the proof load may be applied to the FROG-XT6 either solely on the floor or split between the floor and seats. For the latter the recommended distribution is;</p> <ul style="list-style-type: none"> i. 660 kg (1,455 lb) on seats spread equally between them. Seats and harnesses should be protected prior to loading with weight. If solid test weights are used the seats may be folded to create a flat platform. Wooden boards placed on folded seats will increase area for test weights, the test load should be concentrated towards the centre of the unit to prevent damage/bending to the backrest. ii. 1,200 kg (2,645 lb) placed on the floor and distributed evenly.
Basis of Test Proof Load	Twice Maximum Gross Mass, less Tare Weight* = 2 x 1200 kg – 540 kg = 1860 kg (4,100 lb)
Crane Hook Load	2400 kg (5,291 lb)
Test Method	Lift the unit and hold static for 3 minutes.
Order	1 st - Main Lift Point 2 nd - Backup Lift Point 3 rd - Handling Point

* Note: The tare weight of the FROG-XT6 is approximately 540 kg (1,190 lb) but may vary slightly. Each unit must be weighed prior to load test

Inspection Data Plate

An inspection data plate will be issued and attached by the test house, which should show:

- i. Tare weight (kg)
- ii. Pay load / SWL (kg)
- iii. Maximum gross mass (kg)
- iv. The load test date (DD/MM/YYYY)
- v. Test load (kg)
- vi. The serial number of the FROG-XT: XT6-XXX (where XXX is unit I.D. No)
- vii. The model number of the FROG-XT: XT6
- viii. Entry into service date (DD/MM/YYYY)

Marker Plate

- i. Model number: XT6
- ii. Serial number: XT6-XXX (where XXX is unit I.D. No)
- iii. Date of manufacture (DD/MM/YYYY)
- iv. Tare weight (kg)
- v. Pay load / SWL (kg)
- vi. Maximum gross load (kg)
- vii. Maximum number of passengers (standard & stretcher mode)

Figure 6 FROG-XT Marker Plate



4.8 Pre Use Check

PRE-OPERATIONAL VISUAL CHECK

1	Check LOAD PLATE is fully engaged and secure.
2	Check the LOAD PLATE SAFETY BOLTS are secure and nuts, split pins and tamper-proof seals are in position.
3	Check the NODE PLATE SAFETY BOLTS are secure and nuts, split pins and tamper-proof seals are in position.
4	Check all FITTINGS, FRAME, and BUOYANCY are in good order.
5	Check SEAT HARNESES operate properly and attachment points are secure.
6	Check SUSPENSION SYSTEM operates properly and springs are pre-compressed. SLIDING SLEEVES must be in contact with the stoppers at the top.
7	Check INSPECTION DATA PLATE and all CERTIFICATION are in order.
8	Check WIRE ROPE LIFTING ASSEMBLY is correctly attached and in good order. Check SHACKLE and SPELTER SOCKET safety bolts are fitted with SPLIT PINS . Lifting Assembly should be in the HIGH VISIBILITY COVER .

AW-0032-REV.02
DWG:
RA0105 Rev.B

Original Instructions

Drawing No: RP0108

Revision: C

ECN 186

Issued: 07/08/2014

Page 1 of 1

4.9 Visual Inspection Checklist Form

Frog XT6 Visual Inspection Checklist					
Unit Serial Number		This Inspection Date		Inspected by	
Usage Category		Last Visual Inspection		Position/ Company	
Installation / Vessel		Last Examination		Signature	
Avg. No of Transfers / Year		Last Load Test		Original Inspection record filed in	
Item No	Description	Comment / Serial No./ Colour Code	Pass / Fail	Verified By	
1.	<p>Wire Rope Lifting Assembly (Critical Part) (Consumable) The wire rope lifting assembly (including attachments) must be visually inspected by a Competent Person. Note: High visibility cover must be completely removed to allow inspection of steel wire rope components. It should be replaced according to the usage of the FROG. This may be as frequently as every 3 months. Irrespective of apparent condition the lifting assembly should be replaced at least every 12 months.</p>				
2.	<p>Load Plate Safety Bolts (Critical Part) (Consumable) Visually inspect the 4 x M16 load plate safety bolts, nuts, split pins and tamper proof seals that connect the Load Plate to the central columns for wear or damage.</p>				
3.	<p>Load Plate (Critical Part) Visually inspect in situ for any signs of wear, cracks, deformation or other damage.</p>				
4.	<p>Node Plate Safety Bolts (Critical Part) (Consumable) Visually inspect the 4 x M12 node plate safety bolts, nuts, split pins and tamper proof seals that connect the node plates to the central columns for wear or damage.</p>				
5.	<p>Node Plate (Critical Part) Visually inspect in situ for any signs of wear, cracks, deformation or other damage.</p>				
6.	<p>Seat Base Assembly and the Recoil Dampers Visually inspect for any wear or damage and ensure that all bolts, clevis' and other fasteners are fully secure. Ensure that clevis pin threads are not visible on damper rods. Check to ensure that there is no sign of any fluid leaking onto the damper rods.</p>				

Frog XT6 Visual Inspection Checklist continued...				
Item No	Description	Comment / Serial No./ Colour Code	Pass / Fail	Verified By
7.	<p>Suspension Check the condition of the springs and test the operation of the springs. If the spring shows excessive corrosion or have started to compress then they should be changed out.</p> <p>The springs can be susceptible to yielding over time. This can be verified by measuring the deflection of the seat base in-situ. The following check is recommended to identify whether the springs are fit for purpose:</p> <p>1. In-situ check The top of the sliding sleeve should rest against the compression stop. If a space exists between the top of the sliding sleeve and the compression stops greater than 10mm, then the springs should be replaced.</p> <p>Check the spring cap plate for any signs of deformation.</p>			
8.	<p>Frame and Buoyancy Visually inspect for any damage and ensure that all bolts and fasteners are tight and fully secure.</p>			
9.	<p>Landing Feet Examine the feet to ensure that they are in good condition and that they are properly secured to the capsule. Do not go underneath an active lift. <i>Notes:</i></p> <p><i>i. Measure height of foot and replace if under 100 mm in height</i></p> <p><i>ii. Small (20 mm in length) cuts are acceptable but feet should be replaced when damage larger than 20mm is present.</i></p>	<p>Foot A: B: C: D:</p>		
10.	<p>Seat Harness Security Visually inspect the seat harness attachment points and the harness webbing for any signs of wear, fraying or damage. Check that attachment points are secure.</p>			
11.	<p>Seat Harnesses (sit-in) Sit in each seat and check fastening and unfastening of each harness, to ensure correct operation.</p>			

Frog XT6 Visual Inspection Checklist continued...				
Item No	Description	Comment / Serial No./ Colour Code	Pass / Fail	Verified By
12.	Inspection data plate Check the date of the last examination/ inspection to ensure the unit will remain in compliance with requirements for at least 6 months. Update data plate to show visual examination has been done.			
13.	Stickers - Check that all of the stickers on the unit are in good condition and that none are missing or damaged. The sticker location drawing can be found in the drawing pack.			
14.	Stretcher Fittings – Visually inspect the stretcher fittings to ensure that they are all present and in good condition.			
Storage				
15.	Storage of FROG - Check the storage cover is in good condition and not showing any signs of UV or wind degradation. Storage off the ground , use of spacer chocks whilst not in use			
16.	Replacement Parts Stock - Check condition of all associated replacement parts and accessories. Lifting assemblies should be stored in an appropriate dry place without high visibility cover fitted.			
Reports			Complete Y/N	
17.	Documentation / Report including Photographic Report			
NOTES:				

4.10 Examination Checklist Form

Frog XT6 Examination Checklist					
Unit Serial Number		This Inspection Date		Inspected by	
Usage Category		Last Visual Inspection		Position/ Company	
Installation / Vessel		Last Examination		Signature	
Avg. No of Transfers / Year		Last Load Test		Original Inspection record filed in	
Item No	Description	Comment / Serial No./ Colour Code	Pass / Fail	Verified By	
1.	Wire Rope Lifting Assembly (Critical Part) (Consumable) Replace the wire rope lifting assembly according to the usage of the FROG. This may be as frequently as every 3 months. Irrespective of apparent condition the lifting assembly should be replaced at least every 12 months.				
2.	Load Plate Safety Bolts (Critical Part) (Consumable) Remove and visually inspect the 4 safety bolts for any signs of damage or strain. Visually inspect the 4 holes in the 2 central columns for signs of damage or strain. Replace appropriate parts according to the usage of the FROG XT or on the recommendation of a Competent Person / Inspector.				
3.	Load Plate (Critical Part) Remove and visually inspect the main Load plate for any signs of damage or strain. Replace on the recommendation of a Competent Person / Inspector.				
4.	Node Plate Safety Bolts (Critical Part) (Consumable) Remove and visually inspect the 4 safety bolts for any signs of damage or strain. Visually inspect the 4 holes in the 2 central columns for signs of damage or strain. Replace appropriate parts according to the usage of the FROG XT or on the recommendation of a Competent Person / Inspector.				
5.	Node Plate (Critical Part) Visually inspect the Node plate for any signs of damage or strain. Replace on the recommendation of a Competent Person / Inspector.				

Frog XT6 Examination Checklist continued...				
Item No	Description	Comment / Serial No./ Colour Code	Pass / Fail	Verified By
6.	<p>Seat Base Assembly and the Recoil Dampers</p> <p>Visually inspect for any wear or damage and ensure that all bolts, clevis' and other fasteners are fully secure. Ensure that clevis pin threads are not visible on damper rods. Check to ensure that there is no sign of any fluid leaking onto the damper rods.</p>			
7.	<p>Suspension</p> <p>Check the condition of the springs and test the operation of the springs. If the springs show excessive corrosion or have started to yield then they should be changed out.</p> <p>The springs can be susceptible to yielding over time. The following check is recommended to identify whether the springs are fit for purpose:</p> <p>In-situ check The top of the sliding sleeve should rest against the compression stop. If a space exists between the top of the sliding sleeve and the compression stops greater than 10mm, then the Springs should be replaced.</p> <p>The Recoil Dampers need to be checked too. Ensure that the damper rod-end threads are not visible below the clevis pin eye. Ensure that there is no sign of any fluid leaking onto the damper rods. The Recoil Dampers should also be disconnected at one end so that their operation can be checked and to check for any bowing of the damper rods.</p> <p>Check the spring compression plate for any signs of deformation.</p>			
8.	<p>Frame and Buoyancy - Visually inspect for any damage and ensure that all bolts and fasteners are tight and fully secure.</p>			
9.	<p>Landing Feet</p> <p>Examine the feet to ensure that they are in good condition and that they are properly secured to the capsule. Do not go underneath an active lift.</p> <p><i>Notes:</i></p> <p><i>i. Measure height of foot and replace if under 100 mm in height</i></p> <p><i>ii. Small (20 mm in length) cuts are acceptable but feet should be replaced when damage larger than 20mm is present.</i></p>	<p>Foot</p> <p>A:</p> <p>B:</p> <p>C:</p> <p>D:</p>		

Frog XT6 Examination Checklist continued...				
Item No	Description	Comment / Serial No./ Colour Code	Pass / Fail	Verified By
10.	Seat Harness Security Visually inspect the seat harness attachment points and the harness webbing for any signs of wear, fraying or damage. Check that attachment points are secure.			
11.	Seat Harnesses (sit-in) Sit in each seat and check fastening and unfastening of each harness, to ensure correct operation.			
12.	Inspection data plate Check the date of the last examination/ inspection to ensure the unit will remain in compliance with requirements for at least 6 months. Update data plate to show visual examination has been done.			
13.	Stickers - Check that all of the stickers on the unit are in good condition and that none are missing or damaged. The sticker location drawing can be found in the drawing pack.			
14.	Stretcher Fittings – Visually inspect the stretcher fittings to ensure that they are all present and in good condition.			
15.	Load Test - On critical parts replacement, a load test must be conducted. This is to be done by an independent test house company, nationally recognised and in accordance with ILO 152.			
16.	Post Load Test Visual Inspection – If a load test is done, conduct and report a post load test visual inspection.			
Storage				
17.	Storage of FROG - Check the storage cover is in good condition and not showing any signs of UV or wind degradation. Storage off the ground , use of spacer chocks whilst not in use			
18.	Replacement Parts Stock - Check condition of all associated replacement parts and accessories. Lifting assemblies should be stored in an appropriate dry place without high visibility cover fitted.			

Frog XT6 Examination Checklist continued...				
Item No	Description	Comment / Serial No./ Colour Code	Pass / Fail	Verified By
	Other			
19.	Clean – Has the unit been cleaned			
	Reports		Complete Y/N	
20.	Documentation / Report including Photographic Report			
NOTES:				

4.11 Post Load Test Inspection Checklist Form

Unit Serial Number		This Inspection Date		Inspected by	
Usage Category		Load Test Date		Position/ Company	
Installation / Vessel		Load Test Report/ Ref		Signature	
Avg. No of Transfers / Year		Load Test Authority		Original Inspection record filed in	
Item No	Description	Comment / Serial No./ Colour Code	Pass / Fail	Verified By	
1.	Load Plate (Critical Part) - Visually inspect in situ for any signs of wear, cracks, deformation or other damage				
2.	Load Plate Safety Bolts (Critical Part) (Consumable) - Visually inspect the 4 x M16 safety bolts, nuts, split pins and tamper proof seals that connect the load plate to the central columns for wear or damage.				
3.	Node Plate (Critical Part) - At the bottom end of central columns, visually inspect all of the node plate fittings and check that all bolts are secure. Do not go underneath an active lift.				
4.	Node Plate Safety Bolts (Critical Part) (Consumable) - Visually inspect the 4 x M12 node plate safety bolts, nuts, split pins and tamper proof seals that connect the node plates to the central columns for wear or damage.				
5.	Recoil Dampers Visually inspect for any wear or damage and ensure that all bolts, clevis' and other fasteners are fully secure. Ensure that there is no sign of any fluid leaking onto the damper rods.				
6.	Seat Base Assembly - Visually inspect for any wear or damage and ensure that all bolts and other fasteners are fully secure.				
7.	Suspension - Check the spring condition and test the operation of the spring. Check that the top of the sliding sleeve is engaged against the compression stops.				
8.	Landing Feet - Examine the feet to ensure that they are in good condition after the load test. The feet will normally recover full height sometime after the load test weight is removed.				
9.	Frame and Buoyancy - Visually inspect for any damage and ensure that all bolts and fasteners are tight and fully secure.				
10.	Inspection data plate- Check the date of the last load test has been correctly inserted and is indelibly legible.				
	Reports		Complete Y/N		
20..	Documentation / Report including Photographic Report				
NOTES:					

5 Handling & Storage

5.1 Stock Inspections

These guidelines are for the stocking of new units and parts before they are put into service. These guidelines are NOT applicable to units and parts that have already been put into service.

Table 10 Stock inspections

Type	In Stock Inspection	Release Inspection	Additional Certification	Shelf Life	Actions
Transfer capsules	Annual visual inspection	<p>Less than 2 years old visual inspection</p> <p>Older than two years visual inspection, load test and post load test inspection</p>	<p>1. New inspection date to be stamped on inspection data plate</p> <p>2. Visual inspection checklist to be completed</p> <p>3. For units older than two years the new load test date should be stamped onto the inspection data plate and a new load test certificate issued.</p>	5 Years	<ol style="list-style-type: none"> 1. Remove lifting assembly 2. Place lifting assembly into dry storage 3. Ensure the unit is chocked up off its feet, stored in a secure area away from the risk of damage and protected from exposure to the elements 4. Update certification pack with new lifting assembly information if original lifting assembly is not being used. 5. Update the certificate pack with all new certification documents, including load test and examination certificates.
Wire Rope Lifting Assembly	Visual – Every 6 months	Thorough Examination	<ol style="list-style-type: none"> 1. Re-validated Certificate, indicating next inspection date 2. Certificate of thorough examination should be issued. 	2 Years	<ol style="list-style-type: none"> 1. Keep off the ground in dry and ventilated storage area with the lifting assembly cover removed.
Other replacement Parts (not lifting assemblies)	None	Visual Inspection	Not Required	Unit Lifetime	<ol style="list-style-type: none"> 1. Keep in clean dry storage

Note: When a carrier first enters service, this date must be stamped onto the unit data plate.

5.2 Forklift

Care should be taken when handling with a forklift truck to avoid damaging the underside (landing feet, pillar struts or base of the central lifting column). Alternatively the capsule may be secured to a pallet specifically designed for use with forks.

5.3 Crane

When lifting the carrier with short chain or strop, a temporary shackle should be fixed to the handling lifting point. Care should be taken not to damage the lifting assembly. Shackle should not be fitted through the thimble of the lifting assembly eyes.

5.4 Securing

For deck fastening, place straps across the floor grating.

5.5 Inspection

Before and after transportation the carrier should be inspected to check for damage sustained in transit. The unit must not be used if any structural damage is observed. If any damage has been observed a visual inspection should be carried out to determine the extent of the damage.

5.6 Preparation for Road Transport

Prior to shipping, the seat harnesses should be secured by fastening the buckle together and then tightening the harness straps. This will prevent seat harnesses flapping and damaging the seating area. It is recommended that the carrier is covered for shipping either with a FROG-XT weatherproof protective cover or other heavy duty tarpaulin material.

5.7 Shipping

The FROG-XT6 will fit in a standard or high-cube container. If it is transported on flat rack it should be secured. Recommended securing points are the pillar struts and the back-up eye. To protect it from excess loading, the main Lift-Eye should not be used as a securing point. Feet should be supported to prevent collapse, this can be done by placing suitable chocks or props under the unit.

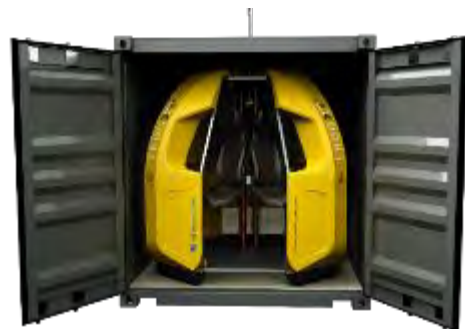

5.8 Storage

The FROG-XT range has been designed to cope with the harsh conditions on an offshore installation or vessel; however it is important to protect the unit as much as possible from any hazardous elements and UV degradation. It is recommended that the FROG-XT is stored under a FROG-XT weatherproof cover whilst not in use.

5.9 Feet Deformation during Storage

Prolonged periods of exposure to hot decks and self-weight can cause permanent set deformation of the elastomeric feet. If the carrier is to be stored for prolonged periods, a set of chocks should be used to lift the feet away from the deck. Any chocks used should fit properly underneath the main base frame to ensure that any exposed bolt heads are not impinged. The chocks are pre-laid on the deck ready for landing the Frog directly to the storage position.



5.10 Replacement Parts

Replacement parts should be stored in dry clean environments and be suitably labelled and tagged.

6 Replacement Parts

6.1 Introduction

Replacement parts can be supplied as individual items or as appropriate kits. Prior to ordering any replacement parts or kits, establish the serial number which is stamped on the data plate. The serial number is XT6- XXX where XXX represents a three digit number. Reflex Marine holds replacement parts and accessories in stock. We are able to supply most individual components. A full list of parts is contained in the customer drawing pack, which is issued with every unit.

It may be advisable to hold an inventory of frequently replaced parts. This will help to ensure the continued safe operation of the carrier. Minimum stock quantities shall be influenced by:

- i. Remoteness of location
- ii. Downtime implications
- iii. Criticality of maintaining crew and emergency response (Medevac) access.
- iv. Usage
- v. Customs processing time
- vi. Delivery cost for small parts

Reflex Marine can recommend stock items and quantities for your operation.

It is recommended that only genuine OEM parts (including lifting assemblies) are used.

6.2 Kits

The following kits are available for routine and non-routine maintenance. Ordering an appropriate kit is more economical than replacing individual parts.

Kit Name	Part Number	Contents
Lifting Assembly Kit	RA0116	Wire Rope Lifting Assembly Lifting Assembly Cover Associated Fixings
Replacement Parts Kit	RA0117	Critical Parts Minus The Wire Rope Lifting Assembly
Critical Part Kit	RA0090	Critical Parts
Harness Kit	RA0295	6 X Harnesses plus Associated Fixings
Landing Foot Kit	RA0303	4 X Feet plus Associated Fixings
Full Service Kit	RA0293	1x Lifting Assembly Kit 1 X Replacement Parts Kit 1 X Harness Kit 1 X Landing Foot Kit 1 x Suspension Kit
Suspension Kit	RA0294	4 X Springs 2 X Recoil Dampers Associated Fixings

6.3 Parts identification

Each assembly or part is assigned a part number which provides the unique identification of the part /assembly.

Where material grades and material traceability are deemed to be safety critical these components will be allocated unique component numbers which will be stamped or etched as required.

Components that require unique identification are referenced in the parts list.

For bolts, where etching is impractical, batches will be colour coded and a note added to the mill certificate to identify the colour used.

6.4 Accessories

The following accessories are available from Reflex Marine to maximise operational effectiveness. They can be supplied with the carrier or ordered separately.



Strobe Light

Provides greater visibility at night and in poor weather conditions. High-intensity: light weight, waterproof to 300 m, Flash Rate 50 per min and also provides 6 mile visibility. Battery powered, fitted to the overhead protection plate of the FROG-XT.

Note: This strobe is not certified for use in hazardous areas. A zoned strobe light is available on request.



Basket Stretcher

Essential for conducting emergency medical transfers, Reflex Marine supply a rigid stretcher that is compatible with the FROG-XT6.



Protective Cover

A silver reflective protective cover which is made of flame resistant fabric (BS7837) and protects against degradation from UV light and the weather.

Luggage Options

Light Luggage Holder

This is a small holder that attaches to the underneath of 2 seats, allowing for small, hand-held items such as laptop bags to be loaded and transported by the FROG-XT6.

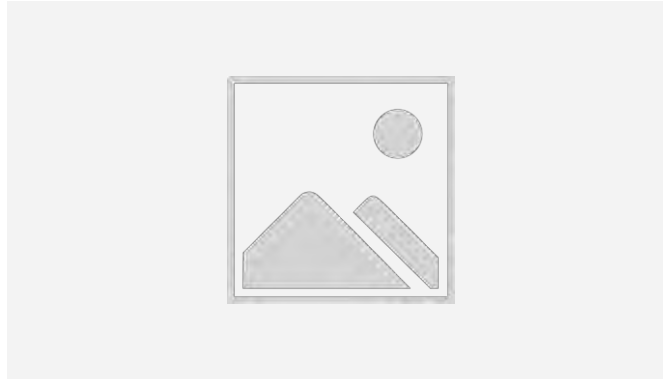

Large Luggage Trays

RML can provide a solution for larger items of luggage that will not fit into the light luggage holder. It is attached to the floor grating underneath the passenger seat. Please contact RML for further information.

For a complete list of accessories please contact RML

7 Certificates

7.1 EC Attestation of Conformity

CERTIFICATE ♦ CERTIFICADO ♦ CERTIFIKAT ♦ CERTIFIKAT ♦ CERTIFICATE ♦



Attestation of Conformity

No: MAC000005 101

Holder of Certificate	Reflex Marine Old School House, School Hill, Shortlanesend, Truro, Cornwall, TR4 9DU, UK
Location of Equipment	Woolard and Henry, Stoneywood Park, Dyce, Aberdeen AB21 7D2, UK
Product/System	XT8 Personnel Transportation capsule
Test/Assessment Reports	75926574 Issue 1
Standards	BS EN ISO 12100: 2010
Technical Documentation File Identity	DP-0127-REV.01

This Attestation of Conformity is issued on a voluntary basis according to Council Directives 2006/42/EC related to Machinery. It confirms that the listed equipment, which is not listed under Annex IV of Directive 2006/42/EC, complies with the protection requirements of the listed Directive. It refers to the sample submitted for testing and inspection and only relates to this sample in the build state and configuration at the time of test/inspection.

Date 09-09-2014 

TÜV SÜD BAST is an accredited Certification body of TÜV SÜD. This Attestation has been issued in accordance with the Certification Regulations of TÜV SÜD BAST. For further details related to this attestation please contact BAST@tuv-sud.co.uk

The CE marking may be used on the equipment described above subject to the equipment meeting the requirements of all applicable Directives, and the issue of all necessary documentation including the Declaration of Conformity.

TÜV SÜD BAST • TÜV SÜD Group
Orpington House • Conesville Way • Farnham • Hampshire • PO15 5RF • United Kingdom

8 Contact Details

Address:

Head Office
Reflex Marine,
Old School House
School Hill
Shortlanesend
Truro
TR4 9DU
UK

Telephone:

+44 (0)1872 321155

Email Addresses:

General enquiries – info@reflexmarine.com

Order enquiries (sales & replacement parts) – support@reflexmarine.com

Accounts Department – accounts@reflexmarine.com