



بلدية دبي
DUBAI MUNICIPALITY

SANITZ PRO

SANITIZATION TUNNEL

Manufactured & Marketed By



PROFEN General Trading LLC

An ISO 9001-2015

P O Box 181926, Dubai, UAE. Tel : +971-4-2515596

www.profenuae.com



SALIENT FEATURES OF AUTOMATIC DISINFECTION TUNNEL FOR HUMAN BODY

- Specially manufactured and approved disinfectant is atomized around the human body, while the person moves through the tunnel.
- The atomizers are placed carefully in a manner to superficially cover the person with disinfectant.
- This superficial layer of mist will neutralize any SARS-CoV-2 virus stuck to the body.
- Thus, the disinfection tunnel can be used as a preventive measure to eliminate any contamination on the body of a person.
- The system is designed to operate independently, controlled by a IP65 Rated sensor. As the person walks through the tunnel the atomizers activate to cover the body with a fine layer of disinfectant, without wetting the person.
- Our system is one of the very few approved by Dubai Municipality Health & Safety Division.
- Our Atomizers are specially designed to atomize disinfectant without changing any chemical composition of the disinfectant.



PARTS

Collection & Drain Tray

MULTI HEAD NOZZLE



NOZZLE



CONTROL PANEL



SPECIAL PIPE FOR CHEMICAL ATOMIZATION





ANTI SKID RUBBER MAT

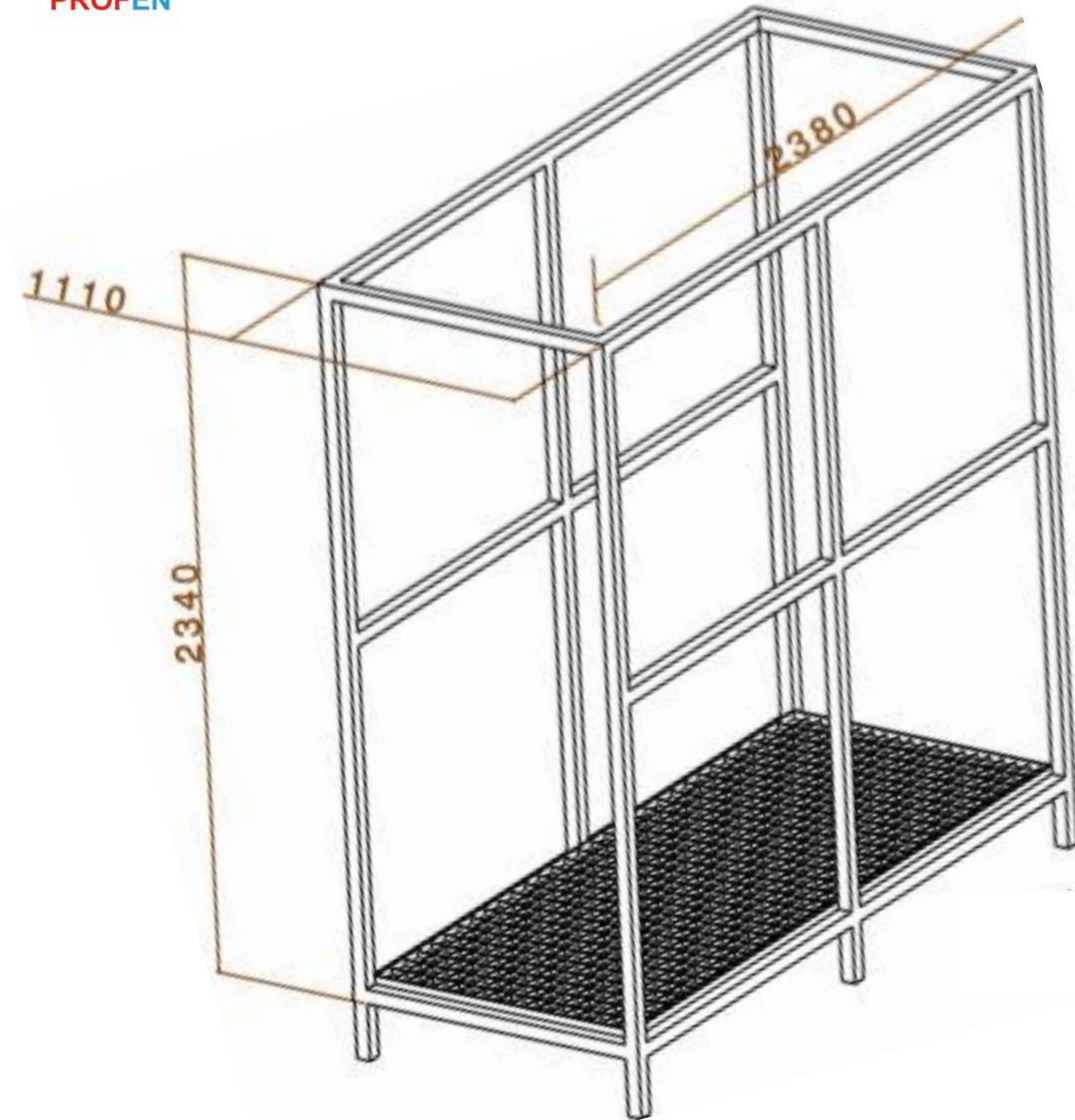



Sr. No.	EQUIPMENT	SPECIFICATION
1	Tunnel shape Human disinfectant	Rectangular
2	Enclosure	Transparent plastic cover with aluminum structure
3	High pressure Pump	misting pump 50-100Bar (0-3LPM)
4	Electric control panel	To control the system
5	Tank	300 Gallon tank
6	Water Consumption	0.5 litre per Minute
7	Power option	220 VAC, 32A /generator operated
8	Sensor for human	Reflective sensor
9	Warranty	12 months from the date of installation
10	Preventive maintenance	Quarterly during the warranty period
11	Structure Dimension	234cm Height , 110cm Width, 238cm Length

- WE ALSO MAKE CUSTOMIZED SANITIZATION TUNNELS
- WE HAVE DIFFERENT MODELS FOR CARS, BUSSES & TRUCKS.

Dubai Municipality
Health & Safety Department
 بلدية دبي
 إدارة الصحة والسلامة

قائمة الشركات المعتمدة لأنفاق تعقيم الأفراد والمركبات
 List of Approved Companies for Individuals & Vehicles
 Sanitizing/Disinfecting Tunnels

DM-PH&SD-L12-LADC

Document Classification (Public) تصنيف الوثيقة (عام)

	Organization Unit: إدارة الصحة والسلامة Document title: قائمة الشركات المعتمدة لأنفاق تعقيم الأفراد والمركبات Doc Ref.: DM-PH&SD-L12-LADC	الوحدة التنظيمية: عنوان الوثيقة: رقم الوثيقة:	
--	--	--	--

رقم التواصل Contact Details	تخصيص نوع النفق Approved Tunnel Type	اسم الشركة Company Name	مسلّم No.
0582055252 taiyab@profenuae.com	للمركبات صغيرة	Profen General Trading LLC بروفين للتجارة العامة - ش.ذ.م.م	1
██████████ ██████████ ██████████	██████████	██████████ ██████████	2
██████████ ██████████	██████████	██████████ ██████████	3
██████████ ██████████	██████████	██████████ ██████████	4
0582055252 taiyab@profenuae.com	للأفراد	Profen General Trading LLC بروفين للتجارة العامة ش.ذ.م.م	5

للمزيد من المعلومات، يرجى التواصل مع إدارة الصحة والسلامة
 For any further information, please contact **Health & Safety Department**

800900 ☎
 ✉ hspemits@dm.gov.ae

Issue date: 7 th April 2020	Superseded Issue Date تاريخ الإصدار السابق	V 1.0
Classification (Public)	NEW	Page 2 of 2