

FULL HIGH DEFINITION 2MP IP PTZ CAMERA

VP-NC8622P-Z32IR5S15 EXPLOSION PROOF CAMERA



FEATURES

Full High Definition 2MP Resolution with H.265 Compression

Inbuilt DWDR, 3D DNR, HLC, Defog & BLC Functions

PD/PP protocol self-adaptive, RS422/485 communication method

304(316) stainless steel surface treated with fluorine-carbon spray, elegant structure, explosion-proof, dust proof, waterproof, rust-proof

Optics class toughened ultra-clear white explosion-proof glass, flux rate higher than 96%

Invisible nano wiper, non-stick water, non-stick oil, dust-proof

Applicable for the factories like oil field, chemical plant, port, oil storage, steamship, oil drilling platform, gas stations, coal mine, aviation, military, steel, firecrackers production, machinery etc

TECHNICAL SPECIFICATIONS

VP-NC8622P-Z32IR5S15

Camera	Image sensor	1/2.8" Progressive Scan CMOS
	Signal System	PAL/NTSC
	Effective Pixels	Full HD/1080P(1920x1080) + Full D1(720x480)
	Minimum Illumination	Color: 0.02Lux @ (F1.6,AGC ON) B/W: 0.001Lux @ (F1.6,AGC ON)
	Electronic Shutter Speed	1/10000s to 1/25s
	Signal to Noise	> 50 dB
	Gain Control	Auto
Lens	Lens Type	4.5mm~144mm 32x Optical Zoom
	Aperture Range	F1.6-F4.8
	Zoom	Approx.3s (Optical Lens, Wide-Tele)
Day/Night Functionality	Day & Night	True Day & Night with ICR
	IR Cut	High performance Mechanical IR Cut Filter with auto switch
	IR Source	Inbuilt Smart IR with intensity control
	IR Range	100m
Compression	Video compression	H.265 / H.264 / MJPEG
Operational Features	Wide Dynamic Range	DWDR
	Rs485 control	Pelco-P, Pelco-D, self-adaptive
	Defog	Supported
	Baud Rate	2,400/4,800/9,600/19,200 bps
	Communication Method	RS422/485
	Automatic Scanning	Supported
	Automatic Cruise	Supported
	Tracking	Supported
	Rotation Angle	Horizontal 0° ~360°, Vertical -90° ~ +90°
	Rotation Speed	Horizontal 0.1°/s ~30°/s, Vertical 0.1°/s ~ 30°/s
	Image settings	ROI, Saturation, Brightness, Chroma, Contrast, Wide Dynamic, Sharpen, NR, Antiflicker, etc. adjustable through client software or web browser
	Security	Watermark, IP address filtering, video mask, heartbeat, password protection
Network & Remote Monitoring	Protocols	IPv4/IPv6, UDP, DHCP, NTP, RTSP, PPPoE, DDNS, SMTP, FTP, SNMP, UPnP, HTTPs, 802.1x, QoS
	System compatibility	ONVIF
	CMS	Full function CMS (Central monitoring software)
	Mobile Client Application	Supports android and iOS APP for Smart phone and tablets
	Bandwidth control	VBR (Automatic) and CBR (Manual) supported
Smart Features	Smart Analytics	Dynamic region, motion detection, intelligent alarm, defog, movement detection
Electrical	Power Requirement	AC220V
	Working Current	≤2000mA
	Electrical Connectivity	Composite Cable
	Automatic Cruise	Automatic Cruise or Any Setting Two Rounds
	Presets	256 Location(Selectable)

TECHNICAL SPECIFICATIONS

VP-NC8622P-Z32IR5S15

Environmental	Material	304 Stainless steel
	Surface treatment	Original Stainless Steel Color, Electropolishing Optional
	Ingress Protection	IP68
	Interface spec	G-3/4"
	Operating Humidity	95%RH(+25°C)
	Operating Temperature	-30°C to +70°C
	Atmospheric Pressure	80-106KPa
	Method of installation	Wall Mounting & Upright Platform Installation
Certificate of Conformity	Marking	EX/ ExdIICT6 Gb / ExtbIIICT(Max 80°C) Db
	Cer. No	IEP 18 ATEX 0549
	Weight	≤28kg
Certifications	Certifications	UL,CE, FCC, RoHS

*Exact products and specifications shown may vary by geographic region and are subject to change without notice. Product image, weights and measurements are approximate and may vary.

DIMENSIONS

Unit: mm

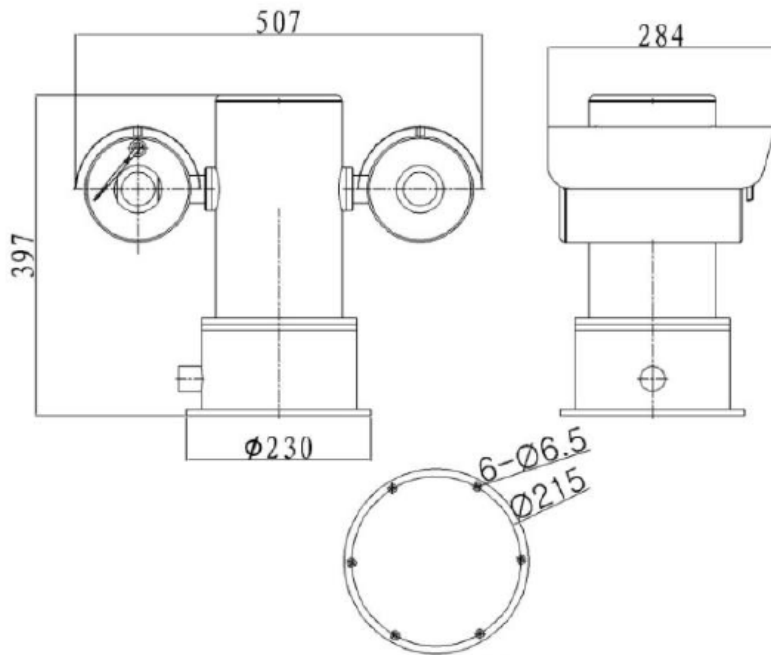

(AN ISO 9001 : 2008, ISO14001 : 2004 CERTIFIED COMPANY)

